

Portable Sewing Table

INSTRUCTIONS

Thank you for purchasing Sullivans' Portable Sewing Table. This table can be assembled with the drawers on the RIGHT or LEFT side (according to your right or left when facing the table. See Page 4). In these instructions, certain steps will be labeled with dual RIGHT SIDE or LEFT SIDE directions. Be sure that you know which side you want the drawers on and follow the appropriate step.

Tools Needed: Phillips head screwdriver, flat-head screwdriver.

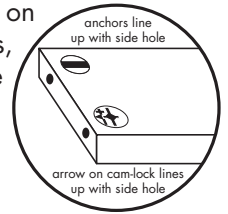

The Drawers

You need: Boards L, M, N, O, and P. Parts Q, R, S, DD, and EE.

1) Take Board L and screw in four Cam Screws (S) into the four plastic inserts. The cam screws should be placed so that there is an inch of the screw left showing.

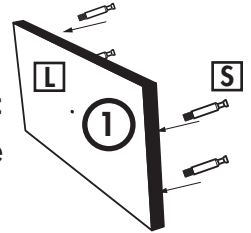

2) Put Board M on the right side of Board L, placing the board onto the cam screws there. There is a groove on both sides of Board M. As shown, the side with the groove nearest an edge should be placed towards the inside of the drawer. Place a Cam Lock (R) in each of the two large holes on the side of Board M where you can see the cam screws from Board L. Turn the cam locks clockwise slowly until they are tight. If the cam locks do not tighten or are unable to turn, check the positioning and length of the cam screws. Repeat this process for Board N.

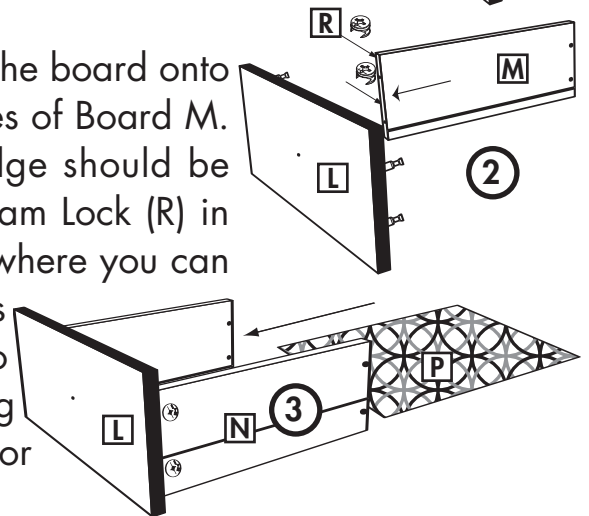

3) Insert the drawer base (P) into the grooves of the current assembly.

4) Take Board O and place a plastic anchor (EE) into each of the four holes on the face. (These anchors may already be placed) Make sure that the anchors (EE) are lined up horizontally in board O. Place Board O into the completed assembly, making sure that the Base (P) inserts smoothly. Screw in four long screws (DD) into the ends of Boards M and N to attach Board O firmly in place.

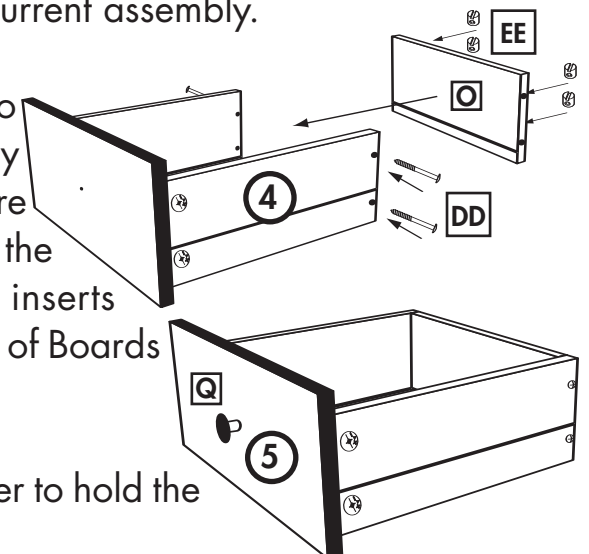

5) Screw the knob (Q) into Board L. Use the screwdriver to hold the screw firm while you twist the knob on.

6) Repeat for each drawer, giving you a total of four drawers.

The Case

You need: Boards C, D, E, F, and J.
Parts R, S, Z, BB, CC, and DD.

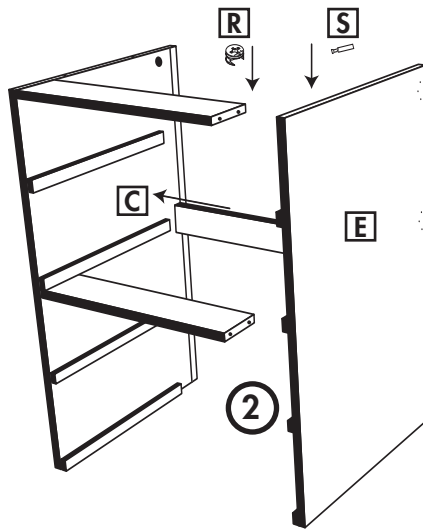

1) Place Board C on the ground with the slotted side facing up. Insert a Cam Screw (S) into each of the six small screw holes on the board. Take each of the three Boards J and place them on Board C. The holes on each Board J should be facing down. Secure the boards with Cam Locks (R).

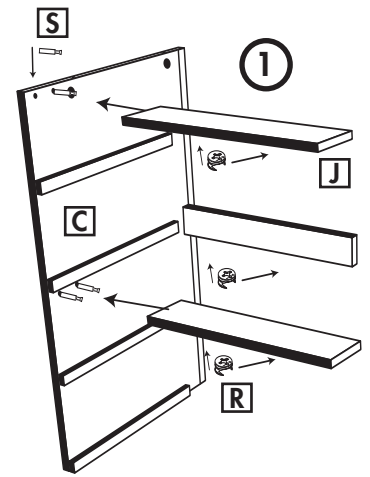

2) Take Board E and insert a Cam Screw (S) into each of the six small screw holes on the board. Place Board E on top of the three Boards J. Secure with Cam Locks (R).

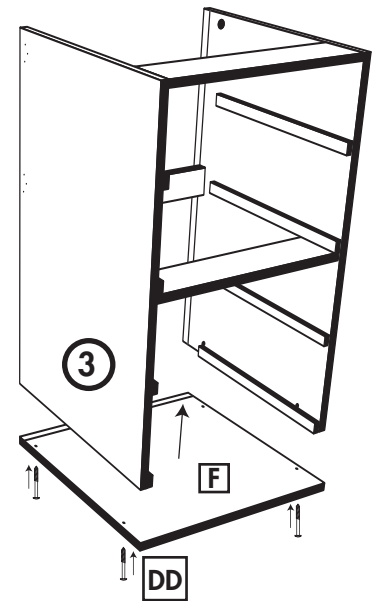

3) Using four long screws and anchors, (DD,EE) attach board F to the base of the current assembly. Be sure that the inset groove on Board F matches up to the grooves on Boards C and E.

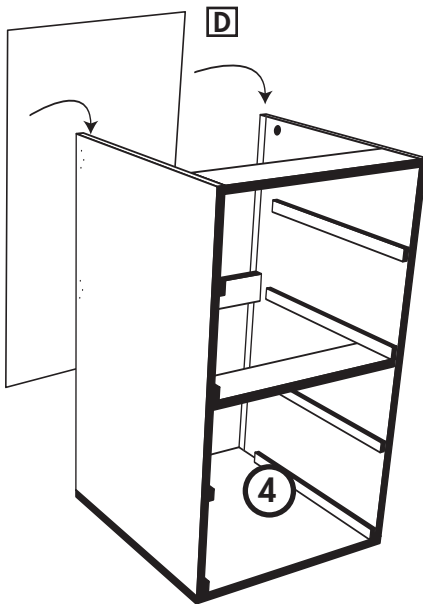

4) Slide Board D into the grooves in the current assembly. Be sure that the board is securely fitted into every groove.

5) Attach the four large coasters (BB, CC) to Board F using the small screws (Z). The locking casters (CC) should go on the front part of the assembly as shown.

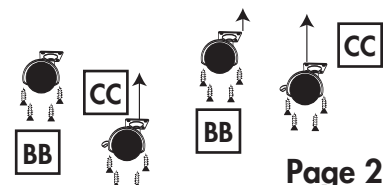
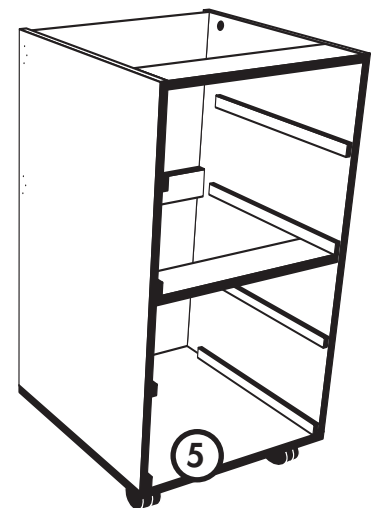

RIGHT SIDE

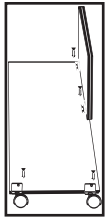

Extending Leg Assembly

You need: Boards G, H, and I
Parts U, W, X, Z, and AA.

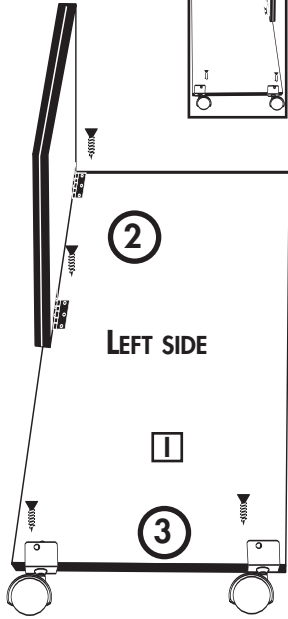
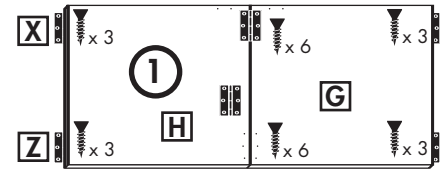

1) Take twenty-four 3/8" screws (Z) and attach six hinges (X) to boards G and H. Make sure that the boards are attached so that the two pre-drilled screw holes in the top corner of each board are close to each other. (see image)

2) Attach the G-H assembly to Board I using two hinges (X) and six screws (Z). RIGHT SIDE: Attach to right side of board I. LEFT SIDE: Attach to left side of Board I (see images).

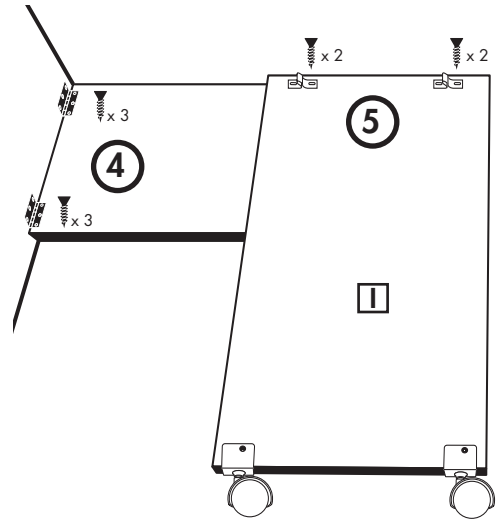

3) Using 3/8" screws (Z), attach the two Leg Casters (AA) onto the bottom of board I. Use the pre-drilled holes on either side of the board.

4) Lay the assembly down so that boards G and H are laying flat and board I is resting on top (see image). Place the case down on its back (board D) and attach the leg assembly. RIGHT SIDE: Board H will attach to Board C. LEFT SIDE: Board G will attach to Board E.

5) Using four 3/8" screws (Z), attach the Spear Strikes (U) to the top of the leg using the pre-drilled holes.

6) Fold the leg assembly in, and stand the table upright on its casters.

7) Fold out the leg, and place the Strike (W) onto the back of extension panel. Use two 3/8" screws (Z).

RIGHT SIDE: Attach Strike (W) to board H.

LEFT SIDE: Attach Strike (W) to board G.

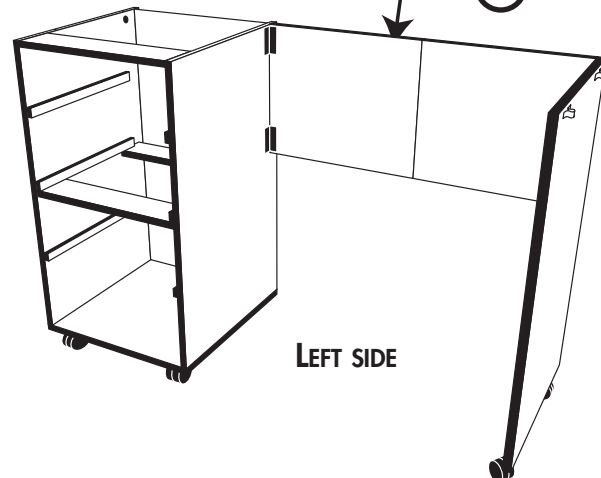
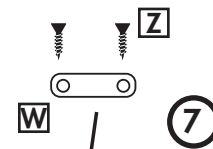

Completing the Table

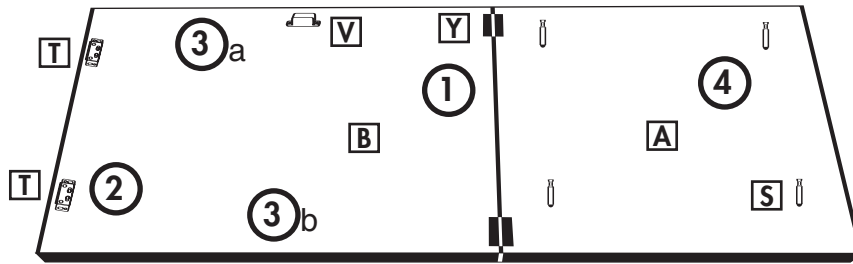

You need: Boards A and B. Parts R, S, T, V, Y, and Z.

1) Attach Boards A and B using twenty 3/8" screws (Z) and two small hinges (Y).

2) Use the 3/8" screws (Z) to attach the magnetic catch (V) to the outside edge of Board B.

RIGHT. SIDE: Place at spot 3a. LEFT SIDE: Place at spot 3b. (see image)

Be sure that the opening in the catch faces outward.

3) Use the 3/8" screws (Z) to attach the roller catch (T) to the edge of the underside of the larger piece (B). Be sure that the opening of the catch faces towards Board A.

4) Place four Cam Screws (S) into the inserts in the smaller section of the assembly (A).

5) Carefully place the table top assembly onto the main body of the table, making sure the Cam Screws are placed into the available holes in the tops of Boards C and E.

6) Secure the table top with Cam Locks (R).

7) Slide the drawers into the main body.

8) Enjoy your table!

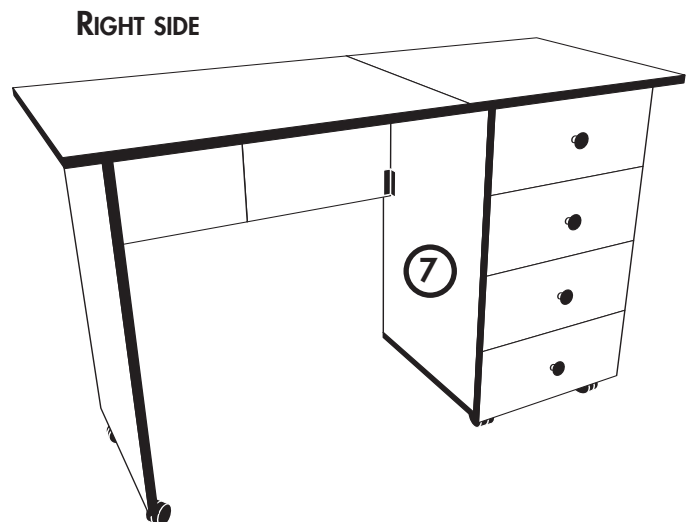
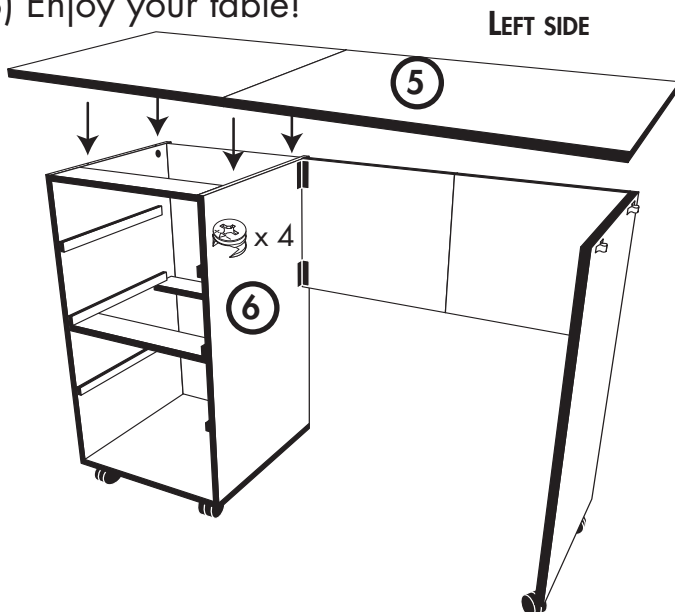

Portable Sewing Table Parts List

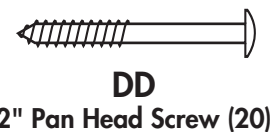
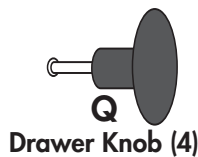
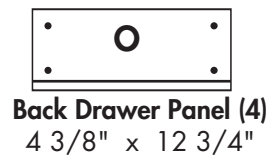
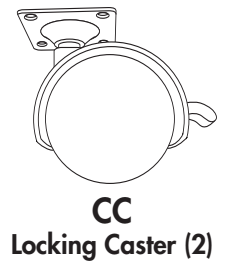
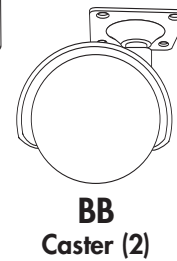
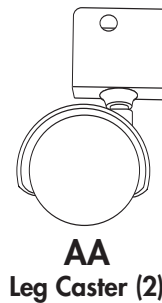
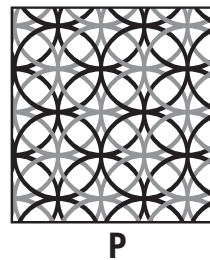
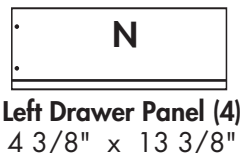
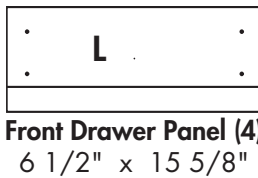
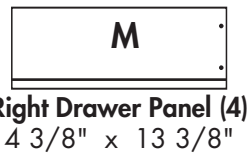
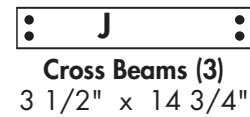
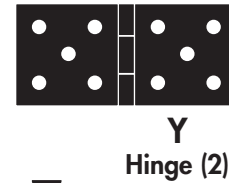
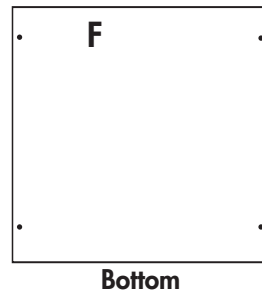
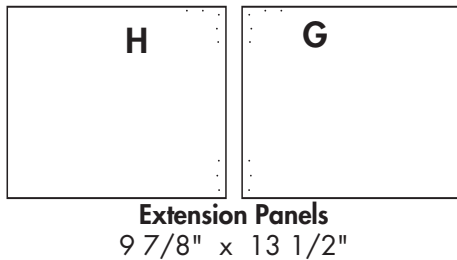
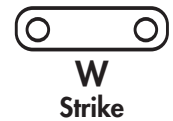
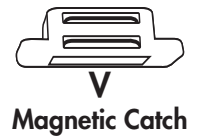
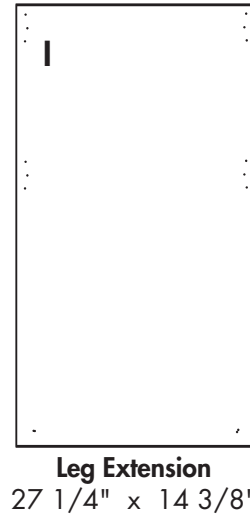
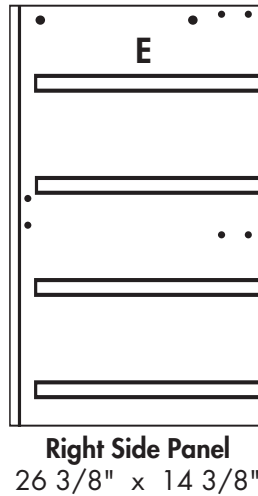
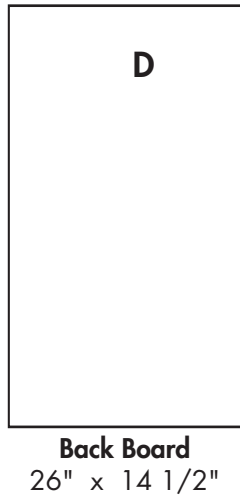
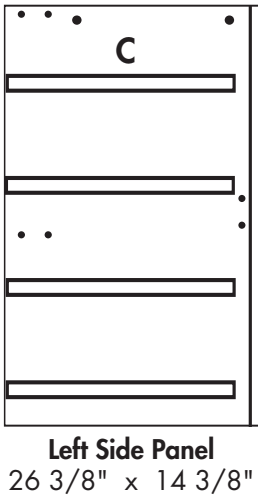
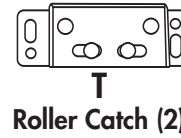
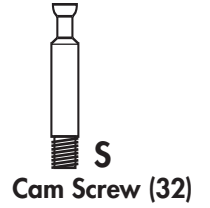
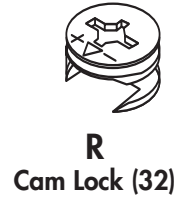
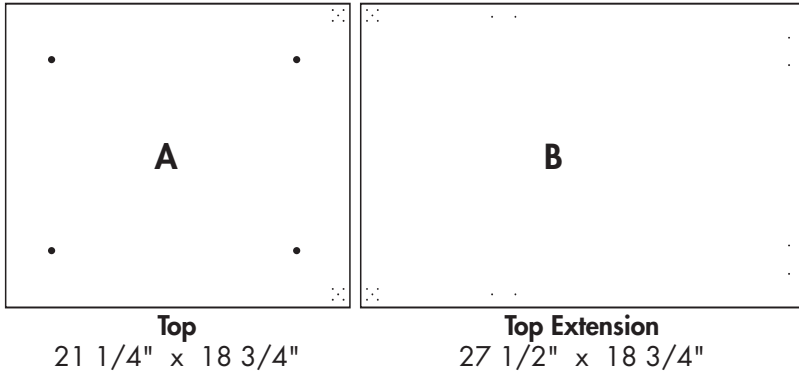



Sullivans USA, Inc. will replace any missing or defective parts within 30 days of purchase. Fax dated receipt to 630-435-1532, along with your request. This policy does not apply to damage due to shipping. For further assistance, please call 800-862-8586.

Clean the table using furniture polish and a soft rag. Do not use harsh chemicals or abrasive cleaners



Sullivans USA, Inc.
4341 Middaugh Ave.
Downers Grove, IL 60515

sulnotions@sbcglobal.net
www.sullivans.net/usa

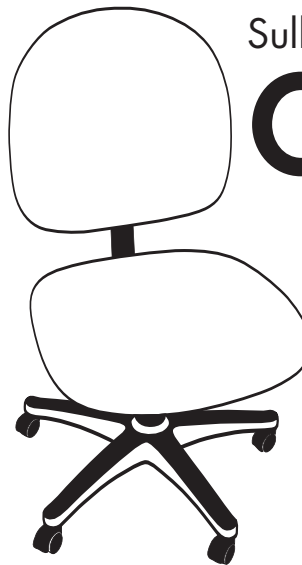

Sullivans'

Comfort Chair

Especially made for the Portable Sewing Table and the Home Hobby Table. Ask about it at your local retailer today!



Also look for

The Home Hobby Table

by Sullivans

Use the portable Home Hobby Table for all sorts of crafts and projects. Fold it up halfway for a smaller working surface, and fold it up completely for easy storage. The table has a completely supported 36" x 59 1/2" laminated work surface and is set at a comfortable 36" height. Sturdy, lightweight metal frame with locking casters.